



# Airworthiness Directive of The Netherlands

Bijzondere Luchtwaardigheids Aanwijzing - BLA

Correspondence address  
P.O. Box 575, 2130 AN Hoofddorp, The Netherlands

**BLA nr. 1993-040/4**

**(B)**

Date : March 31, 2003

## Caution

*In accordance with the Aviation Act 2001 (Wet Luchtvaart), Article 3.22, the following Airworthiness Directive (BLA) is issued by the Minister of Transport, Public Works and Water Management. Airworthiness Directives affect aviation safety. These are regulations which require immediate attention. You are cautioned that no person may operate an aircraft to which an Airworthiness Directive applies, except in accordance with the requirements thereof.*

**LOUIS L'HOTELLIER, S.A.**

**Ball and Socket Connectors**

**EQUIPMENT & FURNISHINGS - BALL & SWIVEL JOINT LOCK PLATES - INSPECTION/MODIFICATION**

**Publication :** Luftfahrtbundesamt (LBA) *Lufttüchtigkeitsanweisung* (LTA) 1993-001/3

**Effective date :** April 15, 1998

**Compliance :** Required as indicated in LBA-LTA 1993-001/3

**Note :** The "recommendation" included in the referenced L'Hotellier Maintenance Instruction to replace the assembly every 10 years or every 3,000 flight hours is **NOT** required by this directive.

**Reason for revision :** Correction of Requirements; Re-inclusion of "Instructions for the Maintenance L'Hotellier Ball and Swivel Joints", Document IMA N°10-01 Revision E (E08-A) dated 03/94.

## Remarks :

- Operators of the affected aircraft may obtain copies of the referenced service information upon request directly from Louis L'Hotellier, S.A., 4 Rue Henri Poincaré, 92160 Antony, France; telephone (33) 1-4666-0808; facsimile (33) 1-4666-2324; e-mail [sylvie.chevallier@lhotellier-sa.fr](mailto:sylvie.chevallier@lhotellier-sa.fr); website [www.lhotellier-sa.com](http://www.lhotellier-sa.com).
- Compliance with this directive must be recorded in the proper Aircraft Log Book(s).
- Where applicable, the requirements of this directive must be integrated into the aircraft's Maintenance Schedule.
- This revision supersedes and cancels Airworthiness Directive (BLA) 1993-040/3 dated March 31, 1998.

Address inquiries concerning this AD to :

Aircraft Division, Section C&D; telephone +31-23-566-3155; facsimile +31-23-566-3006; e-mail [Info.Register@ivw.nl](mailto:Info.Register@ivw.nl).



**Airworthiness  
Directive  
1993-001/3**

**Luffahrt-Bundesamt**  
Airworthiness Directive Section  
Lilienthalplatz 6  
38108 Braunschweig  
Federal Republic of Germany

**L'Hotellier ball and socket connectors**

**Effective Date: April 09, 1998**

**Affected:**

Kind of aeronautical product:	Aircraft
Manufacturer:	L'Hotellier
Type:	L'Hotellier ball and socket connectors with lock plates
Models affected:	ball and socket connectors <u>with lock plates</u>
Serial numbers affected:	all
German Type Certificate No.:	none

**Subject:**

L'Hotellier ball and socket connectors with lock plates if installed in sailplanes, powered sailplanes and aeroplanes

**Reason:**

Reported incidents involving L'Hotellier ball and socket connectors have prompted the LBA to have investigations made as to the operational safety of L'Hotellier ball and socket connectors.

The results have shown that the friction surfaces of the lock plates will be run in and smoothed after a relatively small number of operations. As has been demonstrated in the tests, in this case even normal operating conditions are sufficient under unfavourable circumstances to surmount the static friction (i.e. the lock plates open).

The a.m. airworthiness deficiency may result in inadvertent disconnect of the L'Hotellier ball and socket connectors and thus to considerable operational malfunctions.

Controllability of the aircraft may be affected or even lost so that the defect may lead to an accident.

The reason for the issue of the second edition in April 1994 was the revision of the L'Hotellier Instruction for Maintenance by which the roundness tolerance of the ball was increased from max. 0.05 mm to 0.1 mm.

The ball and socket connectors are to be secured by means of safety pins, Uerlings sleeves or Uerlings type sleeves.

This AD has been issued as a result of several occurrences with Uerlings type sleeves. For well-founded reasons, especially these sleeves are to be inspected for absense of cracks and sufficient self-locking ability and, if necessary, are to be replaced.

**Action:**

The Luffahrt-Bundesamt emphacizes the fact that all pilots have to familiarize themselves with the particularities of L'Hotellier connectors, especially with the different locking systems and their handling.

The ball and socket connectors with lock plates are to be secured. For this purpose, the following actions are to be accomplished:

1. Safety pins (e.g. L'H 140-31 made by Hotellier), have to be retrofitted, if not yet installed. In certain cases, it may become necessary to rebore the hole in the lock plate, which is provided for visual inspection, to  $\varnothing$  1.2 mm so that the safety pin can be inserted (see attachment section I).

The use of a safety pin can be waived if the L'Hotellier ball and socket connector is already equipped with an approved locking system (e.g. Uerlings type sleeve, LS locking sleeve, Schempp-Hirth spring or Wedekind locking system) or if such a system is to be installed.

LBA approved locking systems: see attachment section II.

Uerlings type sleeves (specification number SE-001/78) as well as LS locking sleeves can only be used for straight joints and transmissions, but cannot be used for 90° joints.

*Inspection of Uerlings Type Sleeves*



**Airworthiness  
Directive  
1993-001/3**

**Luftfahrt-Bundesamt**  
Airworthiness Directive Section  
Lilienthalplatz 6  
38108 Braunschweig  
Federal Republic of Germany

Inspection of these sleeves for the absence of cracks and sufficient locking force (self-locking ability), replacement of the sleeves, if necessary (see attachment part III).

**Installation information:**

The sleeves have to be slid axially onto the L`Hotellier ball and socket connector, they may by no means be clipped radially onto the L`Hotellier ball and socket connector. Radial clipping (excessive opening of the sleeve) may lead to cracks or ruptures due to oversteering so that the sleeve cannot function properly any more.

**Annual inspection of sleeves :**

The sleeves shall be inspected at least once a year for the absence of cracks and sufficient locking force (self-locking ability). In the original specification for the Uerlings sleeves a biannual replacement interval is assumed. Deviations from this provision are stated in the technical information by the manufacturers.

**2. Flight Manual**

**a) Section "Rigging"**

The recommendation : „The lock plate of L`Hotellier ball and socket connectors should be secured"... given in several Flight Manuals in the a.m. or in a similar form is to be deleted and to be replaced by the following sentence:

**"The L`Hotellier ball and socket connector must be secured."**

- b)** If older Flight Manuals do not contain information about L`Hotellier ball and socket connectors, section IV (see attachment) is to be included in the Flight Manual under the Section "Rigging", if the L`Hotellier connector is or is to be secured by means of a safety pin. If necessary, the entry is to be included on a new page.
- c)** If Uerlings type sleeves are used as additional locking systems for L`Hotellier connectors, section III of the attachment is to be included in the Flight Manual.

These entries in the Flight Manual may be hand-written or inserted as a copy indicating the AD-No. 1993-001/3 in the Flight Manual.

The amendment is to be entered in the list of effective pages indicating the AD-No. 1993-001/3.

**3.**

**Maintenance Manual**

The enclosed Instructions for Maintenance (L`Hotellier, issue E 03/94) become herewith part of the operating instructions and are to be included in the aircraft Maintenance Manual - as far as this has not been done already by the manufacturers of the sailplanes, powered sailplanes, and aeroplanes concerned.

**4.**

All L`Hotellier ball and socket connectors are to be inspected in accordance with the above Instructions for Maintenance. Connectors exceeding the allowable tolerances are to be replaced.

**Note:**

Type-related technical information already published by the manufacturer or by the product support organisation for L`Hotellier ball and socket connectors become part of this AD.

**The safety pins are available from:**

- L`Hotellier safety pin, reference no. L`H 140-31
- safety pin  $\varnothing$  1.2 mm, Ford reference no. 1473 931 (worldwide)
- manufacturers or product support organisations for the sailplane, powered sailplane or aeroplane types concerned

**Compliance:**

Locking of L`Hotellier connectors:

- on sailplanes and powered sailplanes not later than April 30<sup>th</sup>, 1994.
- on aeroplanes not later than May 15<sup>th</sup>, 1998.

**Inspection of the Uerlings type sleeves on all aircraft:**



**Airworthiness  
Directive  
1993-001/3**

**Luftfahrt-Bundesamt**  
Airworthiness Directive Section  
Lilienthalplatz 6  
38108 Braunschweig  
Federal Republic of Germany

With the next annual inspection but not later than May 15<sup>th</sup>, 1998, and thereafter at least once a year.

**Technical publication by the manufacturer:**

-none-

**Accomplishment and log book entry:**

Action to be accomplished by an approved maintenance organisation and to be checked and entered in the log book by a licensed inspector.

**Note:**

This AD supersedes the AD-No. 1993-001/2 dated April 20, 1994.

**Holders of affected aircraft registered in Germany have to observe the following:**

As a result of the a.m. deficiencies, the airworthiness of the aircraft is affected to such an extent that after the expiry of the a.m. dates the aircraft may be operated only after proper accomplishment of the prescribed actions. In the interest of aviation safety outweighing the interest of the receiver in a postponement of the prescribed actions, the immediate compliance with this AD is to be directed

**Instructions about Available Legal Remedies:**

An appeal to this notice may be raised within a period of one month following notification. Appeals must be submitted in writing or registered at the Luftfahrt-Bundesamt, Lilienthalplatz 6, 38108 Braunschweig

**Attachment to Airworthiness Directive No. 1993-001/3**  
**L'Hotellier ball and socket connector, lock plate**  
Attachment page 1 of 4

**Section I**

**L'Hotellier ball and socket connectors with lock plate**

If the connectors are not yet equipped with safety pins (e.g. I'H 140-31 made by Hotellier), these safety pins have to be retrofitted. In certain cases it may become necessary to rebores the hole in the lock plate, which is provided for visual inspection, to  $\varnothing 1.2$  mm so that the safety pin can be inserted.

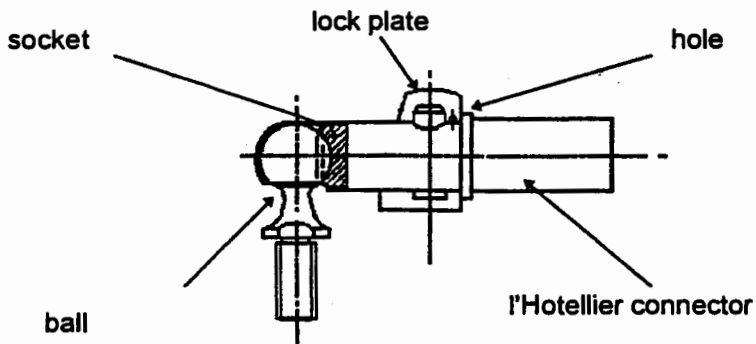

**Warning!**

Unsecured ball and socket connectors may open automatically in flight!

## Attachment to Airworthiness Directive No. 1993-001/3 L'Hotellier ball and socket connector, lock plate

Attachment page 2 of 4

### Section II

#### LBA-approved locking systems

The following systems to secure l'Hotellier ball and socket connectors are LBA-approved: Uerlings sleeves or Uerlings type sleeves (see section III), safety pin (figures 2 and 2a), LS-safety sleeve (figure 3), Schempp-Hirth spring (figure 4) und Wedekind locking system (figure 5).

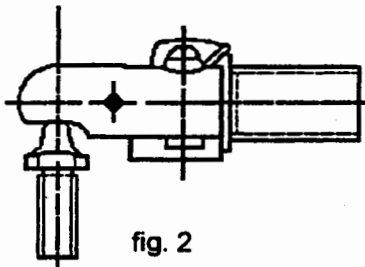

fig. 2



fig. 2a

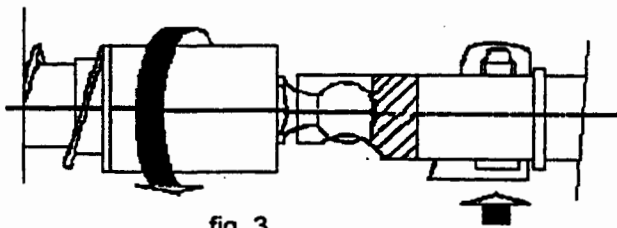

fig. 3

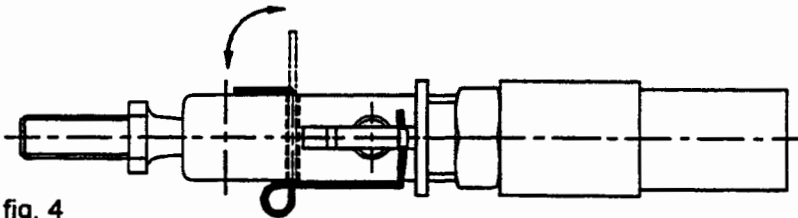

fig. 4

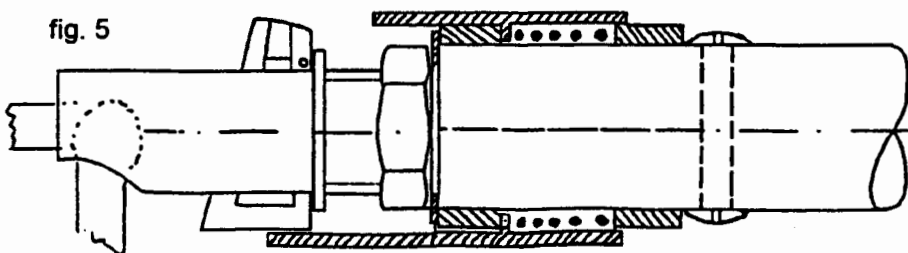

fig. 5

## Attachment to Airworthiness Directive No. 1993-001/3 L'Hotellier ball and socket connector, lock plate

Attachment page 3 of 4

### Section III

#### Installation instruction for Uerlings type sleeves

For installation, the sleeves have to be slid axially onto the l'Hotellier ball and socket connectors.

They may by no means be clipped radially onto the l'Hotellier ball and socket connector. Radial clipping (excessive opening of the sleeve) may lead to cracks or ruptures due to overstressing so that the sleeve cannot function properly any more.

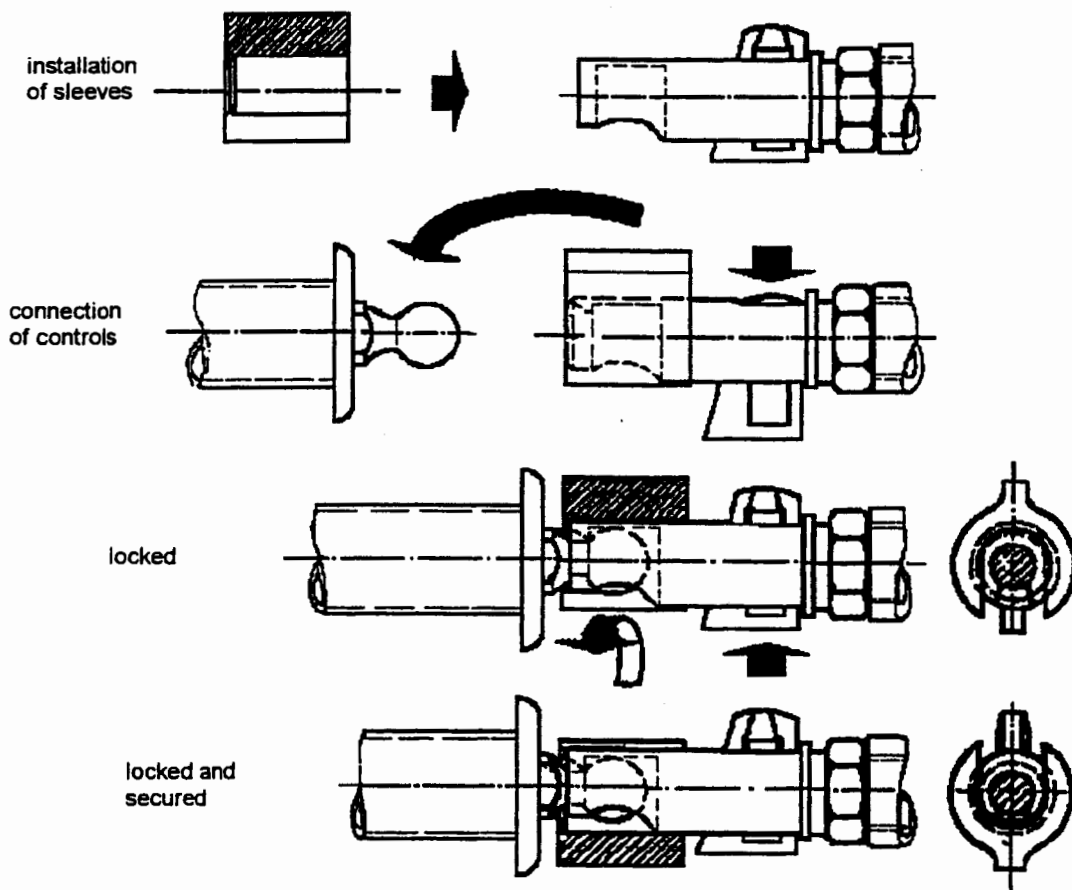

## Attachment to Airworthiness Directive No. 1993-001/3 L'Hotellier ball and socket connector, lock plate

Attachment page 4 of 4

### Section IV

#### L'Hotellier ball and socket connectors

Prior to the installation of ball and socket connectors, everyone has to familiarize himself with their functioning.

The socket is to be slid completely over the ball with the lock plate pressed down. During locking the lock plate moves back slightly so that in a correct connection the hole on the narrow edge of the lock plate becomes visible.

The safety pin is to be inserted in this hole thus securing the ball and socket connector.

#### Attention:

By loading the connection full engagement of the ball is to be verified!

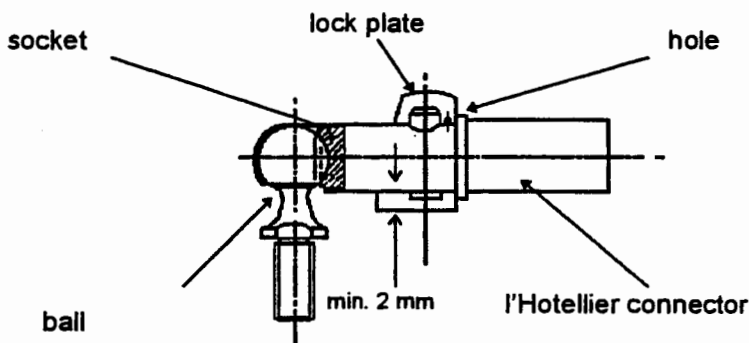

#### Warning!

Unsecured ball and socket connectors may open automatically in flight.



DOCUMENT IMA N° : 10.01 Rev : 3	<b>LTA-Nr.: <u>93-001/2</u></b>	E08-A
---------------------------------------	---------------------------------	-------

## INSTRUCTIONS FOR THE MAINTENANCE L'HOTELLIER BALL AND SWIVEL JOINTS

### HISTORIQUE DU DOCUMENT

REV.	DATE	OBJET DE LA MISE A JOUR	RED.	QUAL.	RESP.
A	11/85	Creation of document	BE	MJD	JMB
B	02/86	Representation of 1 swivel	BE	MJD	JMB
C	01/89	Adjunction of Fig.1 and Fig.2	BE	MJD	JMB
D	07/92	Updating of function of CR147	BE	MJD	JMB
E	03/94	Updating following DEI229-EM	BE	MJD	JMB

### LISTE DES DESTINATAIRES

B.E.	B.C.	OR. +1 EX.	PRODUCTION	1 EX.
Q.C.	B.C.	1 EX.		
Q.C.	C.B.	1 EX.		

BLA nr : 1993-040/4

DOCUMENT IM. N° : 10.01	<b>INSTRUCTIONS FOR THE MAINTENANCE L'HOTELLIER BALL AND SWIVEL JOINTS</b>	<b>E08-A</b>
----------------------------	--	--------------

**COMPOSITION DU DOCUMENT**

PAGE	IND.	PAGE	IND.	PAGE	IND.	PAGE	IND.	PAGE	IND.
TIT	E	SOM	E	1	E	2	E		

**SUMMARY****1 - PREVENTIVE AND SAFETY MAINTENANCE INSTRUCTIONS****2 - PERIODICAL CHECK**

- 2.1. FREE MOVEMENT OF THE BALL INTO THE HOUSING
- 2.2. BALL SPHERICITY MEASUREMENT (See fig. 2)
- 2.3. BALL THREAD CHECK
- 2.4. SWIVEL VISUAL CHECK
- 2.5. MEASUREMENT OF THE LOCKER LOWER PART PROJECTION AFTER ASSEMBLY OF THE SWIVEL ON THE BALL (See fig. 1)
- 2.6. CHECK THE LINK BETWEEN DRIVE ROD AND SWIVEL
- 2.7. SWIVEL LOCK OPERATION CHECK

DOCUMENT IMA N° : 10.01	INSTRUCTIONS FOR THE MAINTENANCE L'HOTELLIER BALL AND SWIVEL JOINTS	E08-A
----------------------------	--	-------

## 1 - PREVENTIVE AND SAFETY MAINTENANCE INSTRUCTIONS

The rotation of the swivel around the ball must be done with resisting strength, due to minimum frictions. Consequently it is mandatory to lubricate the swivel/ball assy. This lubrication must be done after cleaning and before assembly, with a non cold coagulating grease.

Eg : ESSO purpose (general use) :

Spray containing oils enriched with silicone (recommended for assemblies exposed to sand or other abrasive materials).

It is mandatory to verify, after each assembly, the correct location of the ball in the swivel. To do so, a location hole is drilled in the locker. When the assembly is good, the hole must be visible and must enable to insert the pin "B" réf. L'H 140-31, or other devices, linked to the locker only.

## 2 - PERIODICAL CHECK

During the annual visit or no later than every 500 flight hours, it is necessary to verify balls and swivels as follows :

### 2.1. FREE MOVEMENT OF THE BALL INTO THE HOUSING

- Check that the ball move free of friction point.
- Check the angular displacement.
- Check that there is no crack at the base of the ball

### 2.2. BALL SPHERICITY MEASUREMENT (See fig. 2)

The variation between several measures of the ball diameter must not exceed 0,1 mm.

This check aim is to detect an abnormal ball wear.

### 2.3. BALL THREAD CHECK

No thread damage is acceptable. During reassembly the collar must be perfectly set on its base. It is mandatory to fix the ball in position with an adequate locking device.

### 2.4. SWIVEL VISUAL CHECK

No deformation or penning in ball location or in the locking device seat is acceptable.

### 2.5. MEASUREMENT OF THE LOCKER LOWER PART PROJECTION AFTER ASSEMBLY OF THE SWIVEL ON THE BALL (see fig. 1)

This projection must be higher than 2 mm.

The aim of this requirement is to verify the efficiency of the automatic take up clearance

Louis L'HOTELLIER S.A.  
93, avenue Charles De Gaulle - 92270 BOIS COLOMBES  
Tél.(1)42.42.13.94 Téléx 611153F LHOTAIR Télécopie (1)47.60.07.07

RED. : 00      DATE : 03/94  
PAGE            IND. : E

DOCUMENT IMA N° : 10.01	INSTRUCTIONS FOR THE MAINTENANCE L'HOTELLIER BALL AND SWIVEL JOINTS	E08-A
----------------------------	--	-------

**2.6. CHECK OF THE LINK BETWEEN DRIVE ROD AND SWIVEL**

In the case of an adjustable swivel, verify that the link between swivel and drive rod is tight and properly secured by an adequate locking device.

**2.7. SWIVEL ASSY OPERATION CHECK**

Seat or locker : no clamping, due to oxydation or other reason, is acceptable.

If after these verifications, one of the above check is out of tolerance, it is mandatory to replace both ball and swivel.  
nevertheless it is recommended to replace this assembly every 10 years or every 3000 flight hours.

**IMPORTANT NOTE**

Any defected parts may be returned to Ets Louis L'HOTELLIER for technical investigation.

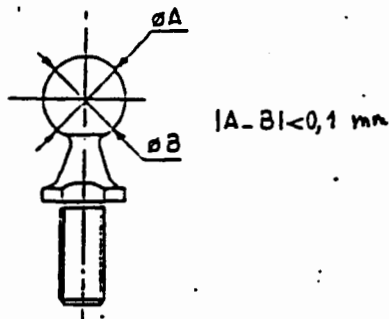
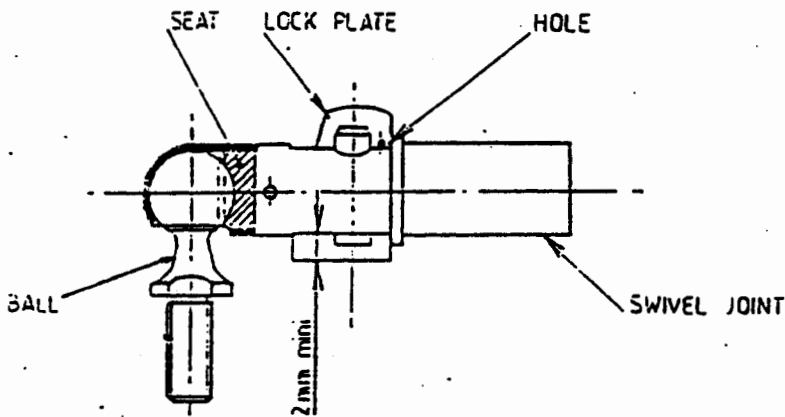

## Vóór het vliegseizoen 'Hotellier' snelsluitingen grondig controleren!

De meeste moderne zweefvliegtuigen zijn uitgerust met snelmontage-koppelingen van het type Hotellier.

Zij vergemakkelijken de montage en zijn ook veilig, mits de behandeling en de aansluiting serieus gebeuren. Dat dit helaas niet altijd het geval is, heeft zojuist het onderzoek van een ernstig ongeval in het buitenland uitgewezen.

Het LBA (de Duitse RLD) heeft derhalve een 'Flugsicherheitsmitteilung' van 1974 vernieuwd uitgegeven om alle piloten op door hen zelf te nemen veiligheidsmaatregelen te attenderen. Dat zijn:

- 1 Steeds vóór het aansluiten de snelkoppelingen en de kogelkoppen goed reinigen en op eventuele beschadigingen controleren. Dan de kogelkop iets invetten.
- 2 Na het aansluiten proberen, met lichte heen- en weerdraaiende bewegingen, de snelsluiters van de kogel los te trekken, met een kracht van  $\pm 5$  kg. Lukt dit niet, dan is de aansluiting goed.
- 3 De in het vlieghandboek genoemde roercontrole moet een vanzelfsprekende routine zijn. Daarbij het betreffende roer vast laten houden. (Deze controle vervangt *niet* de twee eerstgenoemde maatregelen, omdat ze geen absolute zekerheid over de goed zittende aansluiting geeft.)
- 4 Er wordt dringend aangeraden, de zekeringskell bovendien af te zekeren.
- 5 Maak tijdens het lesbedrijf en de typebriefing attent op de mogelijkheid en de gevolgen van een oncorrecte verbinding.
- 6 Bestudeer tijdens de winterpauze in alle rust eens grondig de werking en het systeem van de snelsluitingen.

Frits Höller



- 1 Boringsgaatje
- 2 Holle stift, die het schuiven van de nok begrenst
- 3 Opening voor de aandrijfkop
- 4 Nok met uitholling voor de aandrijfkop
- 5 Keilvormige schuif, die de nok blokkeert
- 6 Huis met veer. De veer houdt de keil in de blokkeerstand
- 7 Afstellingsgedeelte met contramoer
- 8 Aandrijfkop

Lif Thermisch 1984-2